



# TITAN FLOW CONTROL, INC.

## INSTALLATION, OPERATION, AND MAINTENANCE

### PREFACE:

This manual contains information concerning the installation, operation, and maintenance of Titan Flow Control (Titan FCI) Startup (Temporary) Strainers. To ensure efficient and safe operation of Titan FCI Startup Strainers, the instructions in this manual should be thoroughly read and understood. This manual is general in nature and is not meant to take the place of an on-site, process engineer or pipe fitter. As such, Titan FCI recommends that only experienced, skilled personnel be allowed to install and maintain Titan FCI Startup Strainers. Please retain this manual in a location where it is readily available for reference.

### GENERAL INFORMATION:

A Startup Strainer is installed into a pipeline system to remove unwanted debris from the pipeline flow. In contrast to other strainers, Startup Strainers are *temporary* strainers used in pipelines during system startup. Startup Strainers are not designed to be permanent and must be replaced after system startup is completed. Straining of the pipeline flow is accomplished via a perforated or mesh lined screen. In general, the size of the screen perforation should be slightly smaller than the smallest debris particle to be removed. If the screen perforation is undersized, the screen may require excessive cleaning. Consequently, if the screen perforation is oversized, unwanted debris may be permitted to flow through the pipeline; possibly damaging downstream equipment.

For additional information regarding Titan FCI's Startup Strainers, please refer to the engineering specification sheet for each model. Additional information about screen and basket design options may also be found in *Titan FCI's Screen and Basket Selection Guide*.

Prior to selection of a Titan FCI Startup Strainer, the following factors must be determined:

- Material construction requirements of the Startup Strainer.
- Design and working pressure/temperature requirements.
- Operating conditions (throttling, pressure drop, condensation, flow reversal, operation frequency, etc.).
- Service media type (liquid, gas, abrasive, corrosive, dirty, etc.).
- Pipeline Media Flow-rate and Viscosity.
- Clean Start-up Pressure of the Pipeline.
- Space availability for installation.

Please contact a Titan Design Engineer to assist in the determination of these requirements prior to selection and purchase.

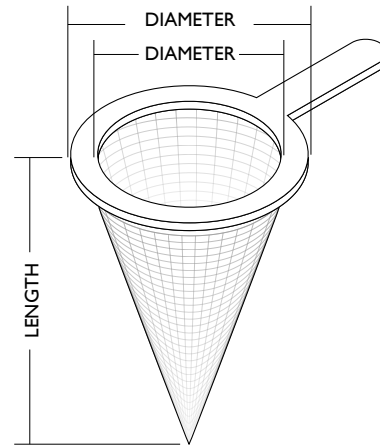

**Figure 1: Style 'D' Startup Strainer Referred to as a Cone or Witch's Hat**

### CAUTION:

Titan FCI's Startup Strainers should only be used during startup operations. They are not designed for long term service and should be replaced with a permanent strainer after startup operations are completed.

### UNPACKING AND INSPECTION:

Upon receipt of product, it is important to follow these unpacking and inspection procedures.

All Titan FCI Startup Strainers are shipped in specialized shipping containers designed to prevent damage during transportation. If external damage to the shipping container is evident upon receipt of product, please request that a representative of the shipping carrier be present before unpacking the product.

- Carefully open the shipping container, following any instructions that may be marked on the container. Remove all packing material surrounding the Startup Strainer and carefully lift it from the container. It is recommended to keep the shipping container and all packing material for reuse in storage or reshipment. For large or heavy Startup Strainers, the appropriate material handling equipment must be used to prevent injury and possible damage to the Startup Strainer.

START-UP STRAINER

1

SU10M1006

YOUR PIPELINE TO THE FUTURE!

Tel: 910-735-0000 ♦ Fax: 910-738-3848 ♦ titan@titanfci.com ♦ www.titanfci.com  
290 Corporate Drive ♦ PO Box 7408 ♦ Lumberton, NC 28358



## INSTALLATION, OPERATION, AND MAINTENANCE

### UNPACKING AND INSPECTION: Continued...

- Visually inspect the Startup Strainer for any signs of damage including scratches, loose parts, broken parts or any other physical damage that may have occurred during shipment. If damage is observed, immediately file a claim with the shipping carrier. Startup Strainers that are damaged during transportation are the responsibility of the customer. For information regarding Titan FCI's warranty policy, please refer to the last page of this document.
- Before installation, the Startup Strainer should be inspected internally for any loose or foreign materials that may have become trapped inside the Strainer during transportation.
- If the Startup Strainer is not required to be installed immediately, it should be stored indoors in a clean, dry, consistent temperature environment. It is also recommended to utilize the original shipping container and packing materials to properly store the Startup Strainer. If long term storage is required, a desiccant may be necessary. This would be based upon the local, environmental storage conditions. Please consult a Titan FCI Design Engineer to assist in this determination.
- When ready to install, remove any preservatives with solvent dampened cloths. Remove any loose material and protective packing material.

### INSTALLATION:

#### Pre-Installation Checklist

- Ensure Working conditions (pressure and temperature) are within the specified capacity of the product being installed. Please refer to the Engineering Specification Sheet for each Startup Strainer model to determine these values.
- Make sure that the construction material of the Startup Strainer is chemically compatible with the media flowing in the pipeline.
- Inspect sealing surfaces that they are clean and smooth (no nicks or cuts). The pipeline should also be checked for proper alignment.

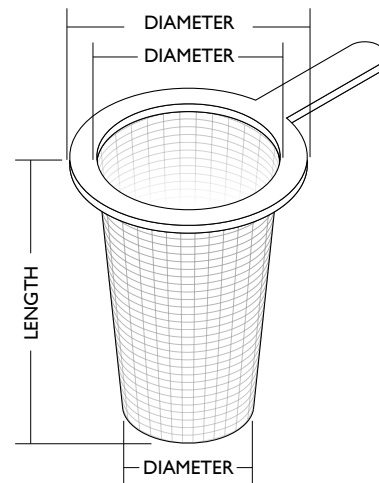

Figure 2: Style 'E' Startup Strainer Referred to as a Basket or Pilgrim's Hat

### INSTALLATION: Continued...

#### Step 1:

Titan Startup Strainers must be positioned in the pipeline ahead of the equipment requiring protection. If the equipment requiring protection is a pump, the Startup Strainer must be placed on the suction side of the pump.

#### Step 2:

Before placing the Startup Strainer into place, support the existing pipeline with pipe supports on either side of the Startup Strainer.

#### Step 3:

Place the Startup Strainer into the pipeline, ensuring that the mesh lined side of the Startup Strainer is facing in the direction of the pipeline flow. For large or heavy Startup Strainers, the appropriate material handling equipment should be used to lift the Startup Strainer into place.

#### Step 4:

If there is a downstream valve on the outlet side of the Startup Strainer, make sure that the tip of the Startup Strainer does not interfere with the opening and closing of the disc, ball, or stem of the valve. This is illustrated in Figure 3.

YOUR PIPELINE TO THE FUTURE!

Tel: 910-735-0000 ♦ Fax: 910-738-3848 ♦ titan@titanfci.com ♦ www.titanfci.com  
290 Corporate Drive ♦ PO Box 7408 ♦ Lumberton, NC 28358

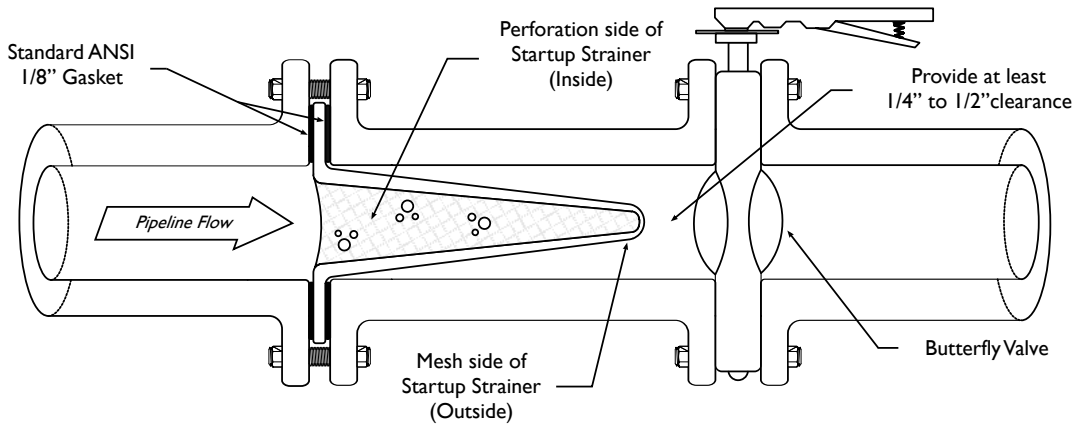

Figure 3: Simplified Drawing of an Installed Startup Strainer

### INSTALLATION: Continued...

#### Step 5:

Install a standard, ANSI (1/8" thick) flange gasket between the Startup Strainer and the pipeline flanges, on both sides. Install lubricated flange bolts and hand tighten. Make sure the Startup Strainer is centered between the mating flanges. Flange bolts should then be tightened, using a star or crisscross pattern to evenly load the bolts, in accordance with established piping standards. This is illustrated in Figure 4.

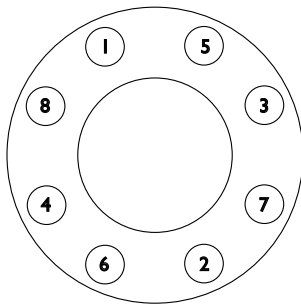

Figure 4: Bolting Sequence Pattern

### CAUTION:

Excessive bolt torque may damage flanges. Please refer to established flange bolt torques for guidelines.

### OPERATION:

Once proper installation has been successfully completed, start the system gradually, at start up as well as after shut down. This eliminates sudden shock to the strainer and other equipment in the line.

#### Start-up Procedure:

##### Step 1:

Remove air from the pipeline by opening a blow-down valve or other vent near the Startup Strainer.

### CAUTION:

With piping systems that contain fluids other than water or when the working temperature is above 120° F, fluid must be drained to safe area, away from the operator. Operators should always be fitted with appropriate protective equipment when venting is performed.

##### Step 2:

Start the piping system by opening the outlet valve nearest the Startup Strainer's outlet first. Then gradually open the inlet valve nearest the Startup Strainer's inlet, approximately 25% of normal operational flow. It is important to start the system gradually to avoid displacing or damaging the Startup Strainer.

YOUR PIPELINE TO THE FUTURE!

Tel: 910-735-0000 ♦ Fax: 910-738-3848 ♦ titan@titanfci.com ♦ www.titanfci.com  
290 Corporate Drive ♦ PO Box 7408 ♦ Lumberton, NC 28358



### **OPERATION:** continued...

#### Step 3:

Continue to open the inlet valve until the desired service flow has been reached.

#### Step 4:

Close blow-down valve or other open pipeline vent.

### **MAINTENANCE:**

Titan FCI Startup Strainers are designed to provide trouble-free service and seldom require maintenance. The pressure differential across the strainer should be checked periodically to determine when the Startup Strainer should be removed.

#### Strainer Removal:

During normal use, the strainer will become clogged with foreign matter, causing the differential pressure to increase. Once the differential pressure has increased to an unacceptable value, typically by 5 psi to 10 psi, it is time to remove the strainer. It is not advisable to let the differential pressure increase by 20 psi. This may cause the screen to fail and possibly damage downstream equipment.

A convenient and safe way to determine when the strainer needs to be removed is to install pressure gauges on the inlet and outlet sides of the Startup Strainer. The maximum acceptable pressure drop across the Startup Strainer will indicate when it should be removed. Strainer size and construction determine the maximum pressure drop a Startup Strainer screen can withstand. Please consult factory for exact pressure ratings.

#### **CAUTION:**

Before removing the Startup Strainer from the pipeline, the pressure inside the pipeline near the strainer must be reduced to atmospheric via suction or venting. Failure to do so may result in serious bodily injury.

#### **CAUTION:**

Before removing the Startup Strainer from the pipeline, ensure that the media that is flowing in the pipeline is known and any special handling precautions are understood. Please review the Material Safety Data Sheet (MSDS) for that specific fluid.

### Strainer Removal: continued...

#### Step 1:

To remove the Startup Strainer from the pipeline, first isolate the Startup Strainer by closing the inlet and outlet valve connections on either side of the Startup Strainer.

#### Step 2:

Open vent or drain plug, near the Startup Strainer, to drain fluid and relieve pipeline pressure. Drain the system as much as possible.

#### Step 3:

Once pressure is relieved and fluid is drained, loosen the flange bolts.

#### Step 4:

Remove flange gaskets.

#### Step 5:

Remove Startup Strainer from pipeline and replace with a permanent type strainer.

### **SPARE PARTS LIST:**

Startup Strainers are designed for temporary service. As such, there are no spare parts. Once the piping system has completed startup operations, the Startup Strainer must be replaced with a permanent type strainer.

*YOUR PIPELINE TO THE FUTURE!*

Tel: 910-735-0000 ♦ Fax: 910-738-3848 ♦ titan@titanfci.com ♦ www.titanfci.com  
290 Corporate Drive ♦ PO Box 7408 ♦ Lumberton, NC 28358



### **WARRANTY:**

Seller warrants each of the products and parts sold hereunder, under normal use of service, and subject to user's compliance with any operating instructions and other directions given by seller, to be free from defects in materials or workmanship for a period of one year from date of shipment from seller's plant. Seller's liability, under this warranty, shall be limited to, at the seller's option, to repairing or replacing any such defective product FOB seller's plant in Lumberton, NC, and reimbursing purchaser for shipping costs, subject to the following: (1) Timely receipt of purchaser's written notice that such products are defective. (2) Seller's written authorization to purchaser for the return of such products. (3) the return of such products to seller with shipping charges prepaid and (4) seller's inspection of and confirmation that such products are defective in materials or workmanship. If seller's inspection shows that the products returned are defective due to dirt, rust or any foreign material not attributable to seller: improper usage, over tightening on threads, abuse or incorrect assembly in the field, or other cause not due to seller's improper manufacture, seller will, subject to purchaser's written authorization, repair or replace such products at cost. Seller's factory inspection and testing reports will be made available to purchaser upon request.

THIS WARRANTY IS IN LIEU OF ANY OTHER WARRANTIES, EXPRESS OR IMPLIED, INCLUDING ANY IMPLIED WARRANTY OF FITNESS OR MERCHANTABILITY. SELLER SHALL NOT BE LIABLE FOR ANY SPECIAL, INCIDENTAL, OR CONSEQUENTIAL DAMAGES. NO REPRESENTATIVE OR SELLER HAS AUTHORITY TO MAKE ANY REPRESENTATIONS OR WARRANTIES, EXCEPT AS STATED HEREIN.



**Figure 5: Style 'E' Startup Strainer  
Referred to as a Basket or Pilgrim's Hat**



**Figure 6: Style 'D' Startup Strainer  
Referred to as a Cone or Witch's Hat**

*YOUR PIPELINE TO THE FUTURE!*

Tel: 910-735-0000 ♦ Fax: 910-738-3848 ♦ titan@titanfci.com ♦ www.titanfci.com  
290 Corporate Drive ♦ PO Box 7408 ♦ Lumberton, NC 28358